

Test - STAAR 04 2013 08 SC E 0

DIRECTIONS

Read each question carefully. For a multiple-choice question, determine the best answer to the question from the four answer choices provided. For a griddable question, determine the best answer to the question. Then fill in the answer on your answer document.

1. Some dairy farmers want to increase the amount of milk produced by their cows. How can the farmers use selective breeding to increase milk production?
 - A. By increasing the age of the cows that are bred
 - B. By choosing cows that are high milk producers
 - C. By limiting the number of offspring per cow
 - D. By choosing cows that can produce milk after eating the most food

2. A balance and a graduated cylinder are used to determine the density of a mineral sample. The sample has a mass of 14.7 g and a volume of 2.2 cm³. What is the density of the mineral sample?
 - F. 0.15 g/cm³
 - G. 32 g/cm³
 - H. 13 g/cm³
 - J. 6.7 g/cm³

3. The three vehicles shown below are all traveling at a speed of 15 m/s, but only the pickup truck has a changing velocity.

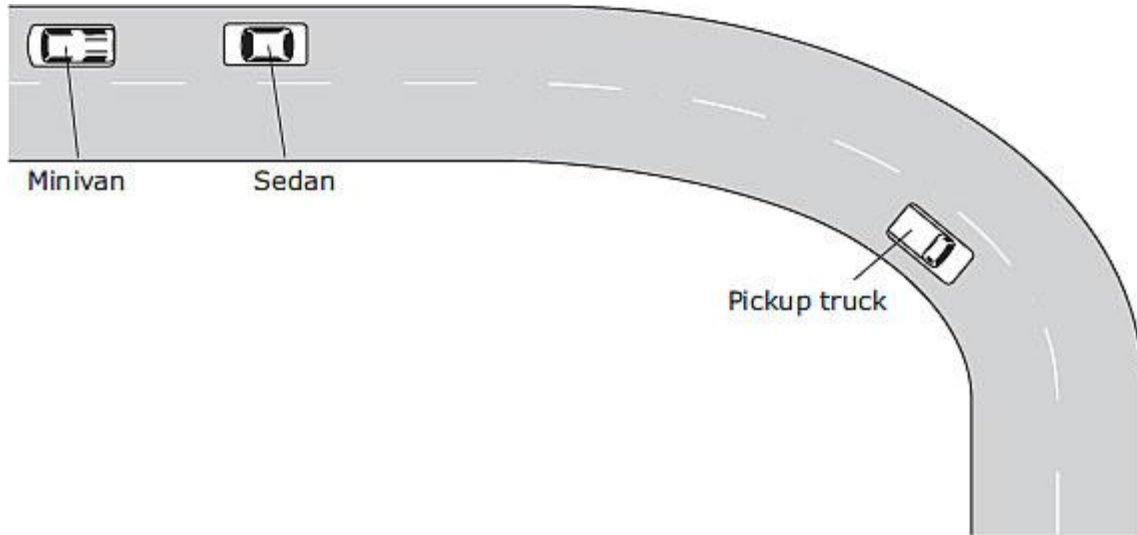

The pickup truck has a changing velocity because the pickup truck —

- A. can accelerate faster than the other two vehicles
- B. is traveling in the opposite direction from the other two vehicles
- C. is traveling on a curve in the road
- D. needs a large amount of force to move

4. The model below shows two continental plates.

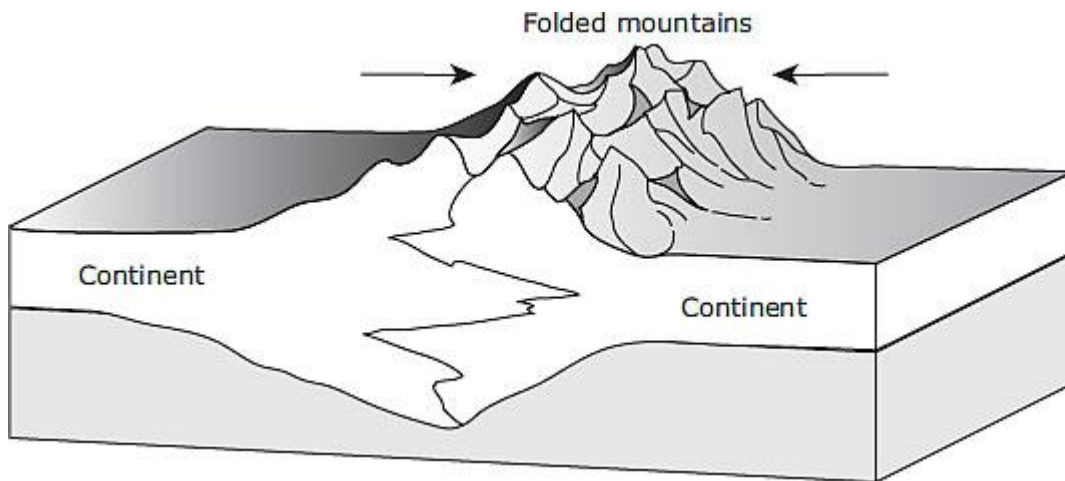

The folded mountains in this model form at which type of plate boundary?

- F. Transform boundary
- G. Divergent boundary

- H. Subduction boundary
- J. Convergent boundary

5. A researcher wants to experiment with an element that reacts like phosphorus (P) but has a greater atomic mass. Which element should the researcher select for the experiment?

- A. Nitrogen (N)
- B. Sulfur (S)
- C. Arsenic (As)
- D. Silicon (Si)

6. Wild Soay sheep live in a cold environment on a small Scottish island. The sheep used to be large because they gained extra weight during the summers in order to survive the harsh winters. A recent change in the island's climate has caused grass to be available for a longer period each year, so survival conditions for the sheep have become less challenging.

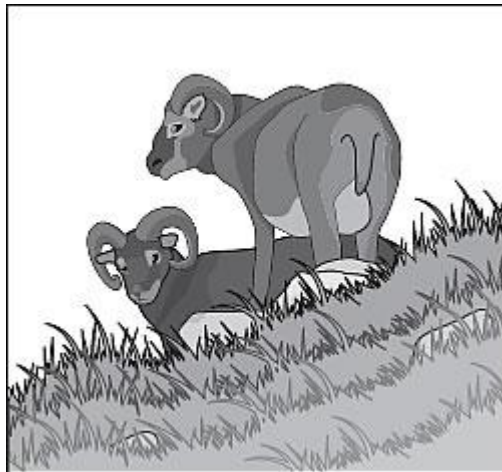

Researchers who study these sheep have most likely observed a decrease in the wild Soay's —

- F. size
- G. life expectancy
- H. reproduction rates
- J. body temperature

7. Two boxes and their masses are shown below.

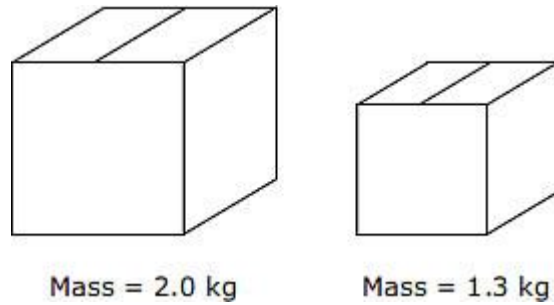

Which of the following situations shows work being done?

- A. A student is sitting in a chair and holding both boxes.
 - B. A student is holding the large box 1 m above the floor.
 - C. A student is standing and holding the small box.
 - D. A student is lifting the small box 0.5 m from the floor to a table.
8. The graph below shows the percent of seeds from two plant species that sprout when grown in water containing different amounts of salt.

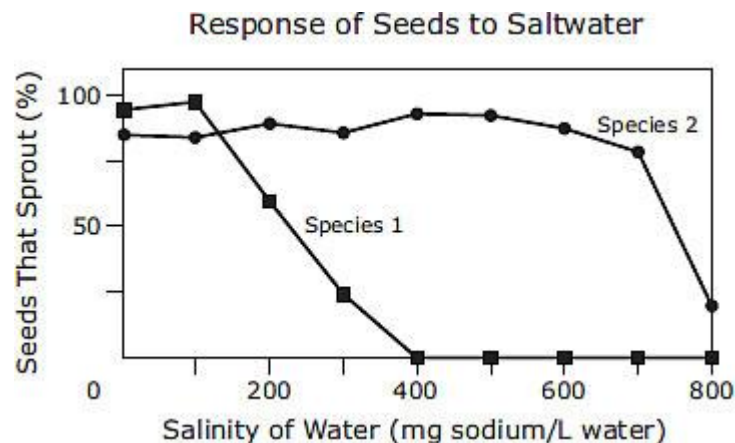

Which of the following best summarizes the effect of saltwater on these plant species?

- F. Species 1 can sprout only in fresh water, and Species 2 can sprout only in saltwater.
- G. Both species can sprout in freshwater and saltwater, but Species 2 can sprout in a higher salt concentration than Species 1.
- H. Both species need salt in their water, but Species 2 needs more salt than Species 1.
- J. Species 1 can sprout only in water with a low salt concentration, but Species 2 is not affected by the salt concentration.

9. The Milky Way galaxy is described as a disk of stars orbiting a central point on the disk. Which of these best explains why people on Earth cannot see the entire shape of the Milky Way?
- A. Earth is a part of this galaxy.
 - B. Many more stars exist outside the galaxy.
 - C. The stars in the center of the galaxy are extremely small.
 - D. The center of the galaxy consists of a dense cluster of stars.

- 10 For an investigation, a student measures the speed of a cart as it rolls down a ramp. The student then records data in the table below.

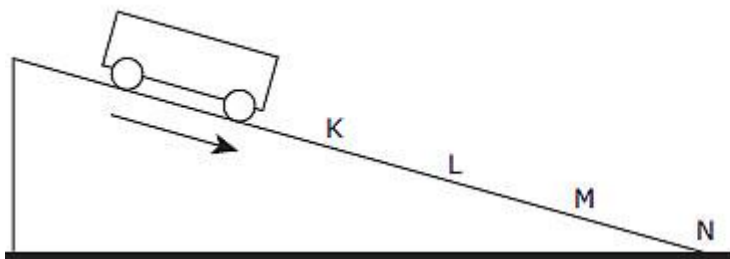

Cart's Speed Down a Ramp

Location	Average Speed (m/s)
K	0.25
L	0.52
M	0.73
N	1.08

Which of these best explains the student's data?

- F. The speed of the cart decreases as the cart rolls down the ramp because of friction between the cart and the ramp.
 - G. The speed of the cart increases as the cart rolls down the ramp because the force acting on the cart is greater than the force of gravity.
 - H. The speed of the cart increases as the cart rolls down the ramp because the forces acting on the cart are unbalanced.
 - J. The speed of the cart decreases as the cart rolls down the ramp because the forces acting on the cart are balanced.
11. A model of an atom is shown below.

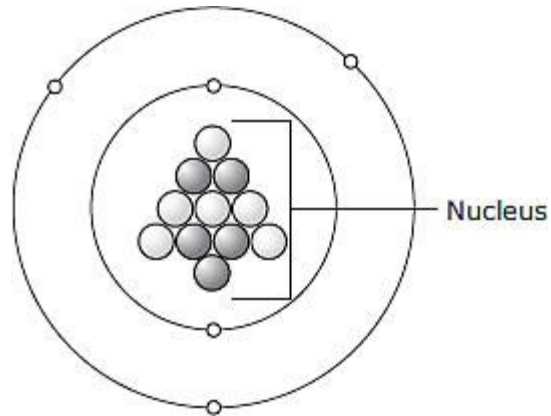

An atom of which element is represented by this model?

- A. Boron (B)
- B. Carbon (C)
- C. Neon (Ne)
- D. Sodium (Na)

- 12.** The satellite photograph below shows a large meteorite crater that is 1200 m in diameter and 170 m deep. This crater is located in a flat, arid part of north eastern Arizona.



How will this crater most likely change over time?

- F.** It will get deeper as it fills with water.
- G.** It will rise up like a volcanic crater.
- H.** It will become less deep as the rim erodes.
- J.** It will widen as it fills with lava.

13. Certain species of whiptail lizards have only female individuals and no males. These lizards reproduce asexually. What is one disadvantage of asexual reproduction for these lizards?

- A.** A new population can be established by a single individual in a relatively short period of time.
- B.** All the members of a population are genetically very similar and less able to survive environmental changes.
- C.** They are smaller than lizards that reproduce sexually.
- D.** They are more likely to develop a variety of tail lengths.

14. Two cars with different masses travel at the same speed down a hill toward a stop sign. What will happen when both cars apply brakes at the same time to stop?

- F.** The car with the smaller mass will require less force to stop than the car with the larger mass.
- G.** The car with the larger mass will maintain its velocity while traveling down the hill.
- H.** The car with the smaller mass will take longer to stop than the car with the larger mass.
- J.** The car with the larger mass will have less inertia than the car with the smaller mass.

15. Which of the following best describes an electron?

- A.** It has no charge and about the same mass as a proton.
- B.** It has a negative charge and much less mass than a proton.
- C.** It has a positive charge and much more mass than a neutron.
- D.** It has a negative charge and about the same mass as a neutron.

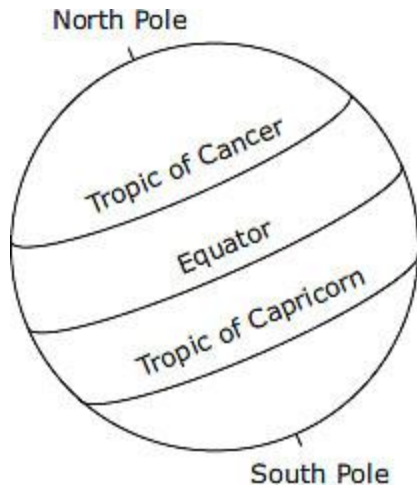

16. Which of these locations on Earth experiences the least change in the number of day light hours throughout the year?

- F. Equator
- G. North Pole
- H. Tropic of Cancer
- J. Tropic of Capricorn

17.

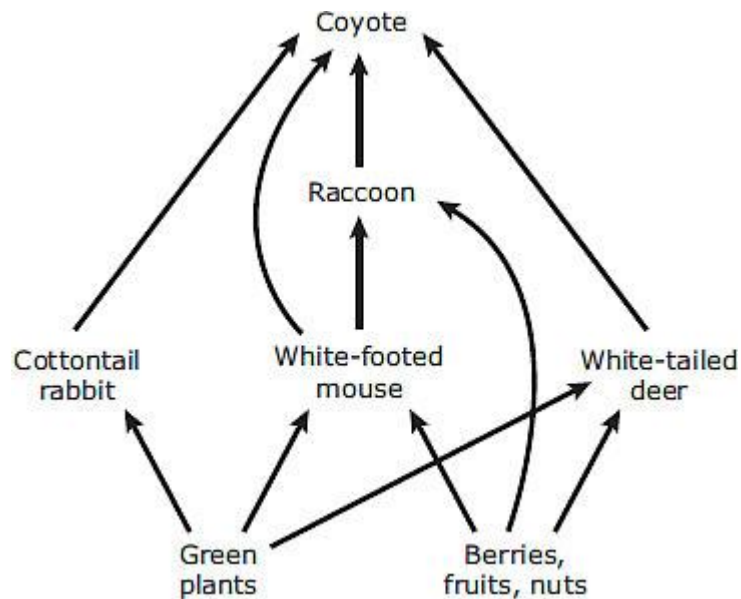

How many organisms in this food web eat only producers? Record your answer and fill in the bubbles on your answer document. Be sure to use the correct place value.

- 18.** A scientist spilled a few drops of dilute hydrochloric acid (HCl) on a lab table. For safety purposes, the scientist sprinkled some baking soda (NaHCO₃) onto the spill. Which observation would provide the best evidence that a chemical reaction occurred?
- F.** The baking soda and hydrochloric acid combined, and bubbles formed.
 - G.** The baking soda absorbed the hydrochloric acid.
 - H.** Some of the baking soda dissolved in the hydrochloric acid.
 - J.** The hydrochloric acid evaporated, leaving only the baking soda.

- 19.** In the classroom demonstration shown below, a rubber ball is dropped from Position 1. The ball bounces as shown.

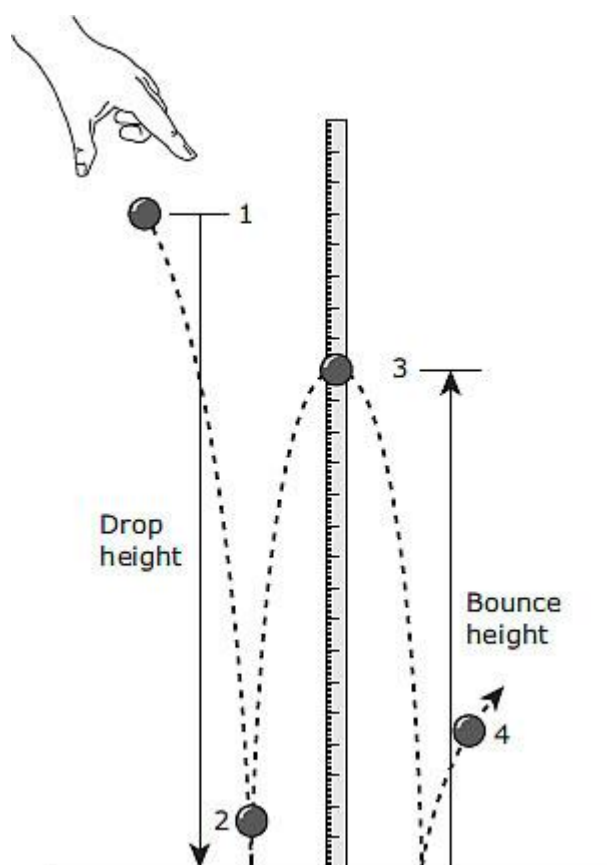

At which of these positions does the ball have both the greatest kinetic energy and the least potential energy?

- A.** Position 1

- B. Position 2
- C. Position 3
- D. Position 4

20. Which information could a student determine from only the chemical formula of a protein?

- F. The color of the protein
- G. The number of molecules in each sequence that makes up a protein
- H. The physical arrangement of atoms in the structure of the protein
- J. The number of atoms of each element in the protein

21. What is one condition that is necessary for a hurricane to form?

- A. Warm ocean water
- B. A strong cold front
- C. Cold ocean water
- D. A strong warm front

22. Four students raced toy cars on a track. The mass and the acceleration of each car is recorded in the table below.

Toy Cars

Toy Car	Mass (kg)	Acceleration (m/s^2)
1	0.19	2.0
2	0.15	3.0
3	0.25	1.5
4	0.21	2.5

Which toy car had the greatest applied force?

- F. 1
- G. 2
- H. 3
- J. 4

23. A teacher asks a student to write the chemical equation for photosynthesis. The student's response is shown below.

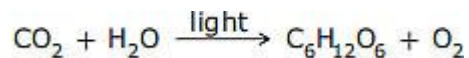

The equation is not balanced correctly. Which of these is a balanced equation for photosynthesis?

- A. $12\text{CO}_2 + \text{H}_2\text{O} \xrightarrow{\text{light}} \text{C}_6\text{H}_{12}\text{O}_6 + \text{O}_2$
- B. $\text{CO}_2 + 9\text{H}_2\text{O} \xrightarrow{\text{light}} \text{C}_6\text{H}_{12}\text{O}_6 + \text{O}_2$
- C. $\text{CO}_2 + \text{H}_2\text{O} \xrightarrow{\text{light}} 3\text{C}_6\text{H}_{12}\text{O}_6 + \text{O}_2$
- D. $6\text{CO}_2 + 6\text{H}_2\text{O} \xrightarrow{\text{light}} \text{C}_6\text{H}_{12}\text{O}_6 + 6\text{O}_2$
24. Some students collected leaf samples. The students used the leaf identification key shown below to identify a leaf sample.

Leaf Identification Key

Step	Characteristic	Species
1a	Simple leaf (single leaf)	Go to 2
1b	Compound leaf (leaves grouped on a stem)	Go to 5
2a	Leaves directly opposite on twig	Go to 3
2b	Leaves not directly opposite on twig	Go to 4
3a	Leaves with 5 lobes	Sugar maple
3b	Leaves with 3 lobes	Black maple
4a	Leaves that are fan-shaped	Ginkgo
4b	Leaves that are star-shaped	Sweet gum
5a	Leaves arranged like a fan	Horse chestnut
5b	Leaves directly opposite on stem	Honey locust

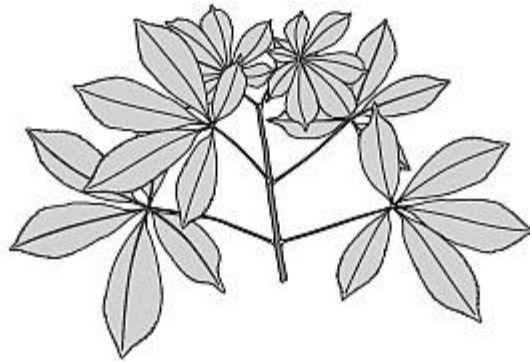

Based on the identification key, which type of tree is this sample from?

- F.** Ginkgo
- G.** Honey locust
- H.** Horse chestnut
- J.** Black maple

25. The diagram below shows four phases of the moon as it revolves around Earth.

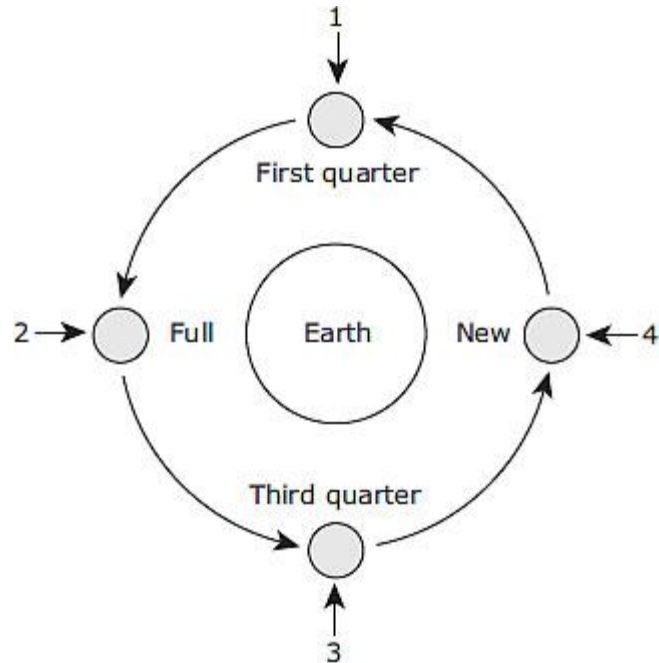

A student builds a model based on this diagram. The student uses foam balls to represent the moon and Earth and a flashlight to represent the sun. The student should shine the flashlight on the model of Earth from Position—

- A. 1
- B. 2
- C. 3
- D. 4

26. An object will continue moving in a straight line unless it is acted on by an unbalanced force. Which of the following best explains Earth's motion?
- F. There is no unbalanced force acting on Earth because space is empty and nothing touches Earth.
 - G. The gravitational force pulling Earth toward the sun is equal and opposite to the force pulling the sun toward Earth, so there is no unbalanced force acting on Earth.
 - H. The sun moves in an elliptical orbit around Earth, and the sun's gravity pulls Earth along.
 - J. Earth moves in an elliptical orbit around the sun because the gravitational force of the sun attracts Earth.

27.

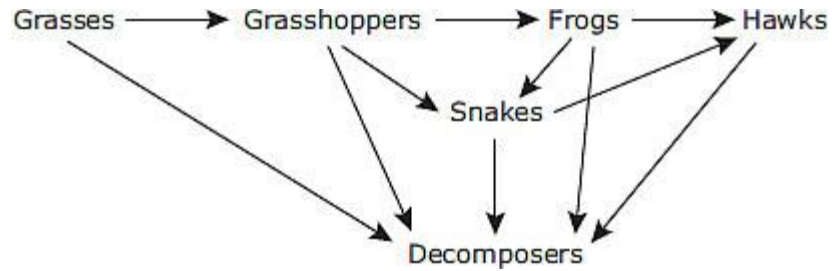

Which organisms in the food web shown above compete for the same food source in this environment?

- A. Grasshoppers and snakes
- B. Hawks and frogs
- C. Frogs and snakes
- D. Decomposers and grasses

28. A car travels at a constant speed of 15 m/s for 2 minutes. The car increases its speed from 15 to 25 m/s during the next minute and then travels at a constant speed of 25 m/s for 2 more minutes. Which of the following graphs best represents the car's motion during this 5-minute period?

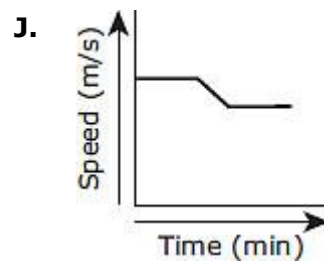
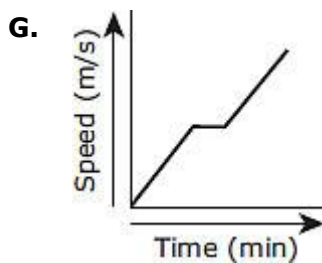
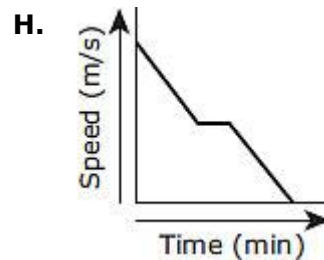
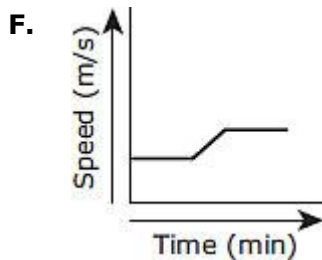

29. While exploring a lake in Argentina, Laguna del Diamante (Diamond Lake), scientists found rocks covered with mats made of photosynthetic microbes. Flamingos in the area filter the nutrient-rich microbes by pumping the lakewater through their bill. What is the relationship between the photosynthetic microbes and the flamingos in the Laguna del Diamante ecosystem?

- A. The microbes are parasites, and the flamingos are hosts.
- B. The microbes are carnivores, and the flamingos are predators.
- C. The microbes are herbivores, and the flamingos are carnivores.
- D. The microbes are producers, and the flamingos are consumers.

30. A student walks 2 km in 30 minutes. What is the student's average speed in km/h?

Record your answer and fill in the bubbles on your answer document. Be sure to use the correct place value.

31. Hay is made up of organic compounds. What are the main elements in many organic compounds?

- A. Helium, carbon, sodium
- B. Sodium, hydrogen, nitrogen
- C. Carbon, hydrogen, oxygen
- D. Radon, oxygen, helium

32. Some students take care of a vegetable garden. When it is time to plant in the spring, the students leave part of the garden empty in order to observe ecological succession. Which of these will most likely occur first?

- F. Development of topsoil
- G. Growth of weeds and grasses
- H. Growth of trees and shrubs
- J. Development of a stream

33. When trying to identify an unknown element, a scientist determines what other elements the unknown element reacts with chemically. Which property of the unknown element determines the other elements it reacts with?

- A. The total number of neutrons in the unknown element

- B. The total number of particles in the nucleus of the unknown element
- C. The number of protons in the nucleus of the unknown element
- D. The number of valence electrons in the unknown element

34. Plants use energy from sunlight, water, and carbon dioxide to produce sugar. Which structure is found only in plant cells and helps plants capture energy from sunlight?

- F. Vacuole
- G. Nucleus
- H. Chloroplast
- J. Cell membrane

35. The thick black lines on the map below show the locations of mid-ocean ridges.

Mid-Ocean Ridges

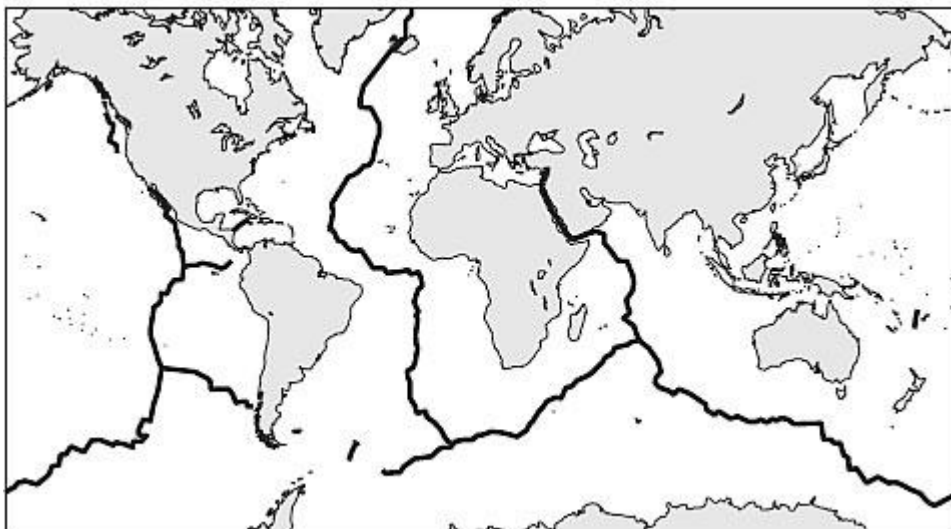

Source: USGS

Which geologic feature is most likely to form at a mid-ocean ridge?

- A. Peninsula
- B. Volcano
- C. Delta
- D. Plateau

36.

Force Acting on Cart (N)	Cart Acceleration (m/s^2)
1	0.2
2	0.4
5	1.0
6	1.2
?	2.6

Some students measure the acceleration of a wheeled cart being acted on by varying forces. The students record their data in the table shown above. According to the data table, how much force is acting on the cart when the students measure an acceleration of 2.6 m/s^2 ?

- F. 13 N
- G. 7 N
- H. 8 N
- J. 12 N

37. The model of the periodic table below shows the locations of four elements.

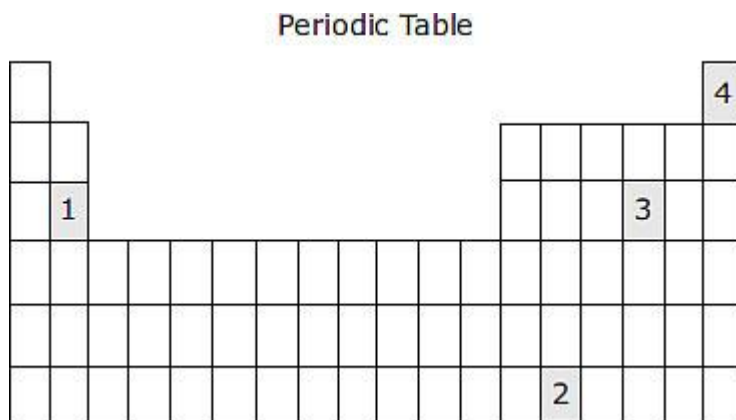

A student is asked to identify an element that is a pale-yellow brittle solid and does not conduct electricity. At which location in this periodic table would the element most likely be found?

- A. 1
- B. 2

- C. 3
- D. 4

38. A section of a topographic map is shown below.

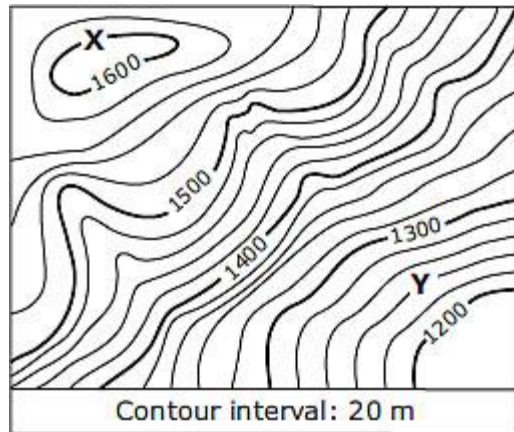

What is the difference in elevation in meters between Point X and Point Y on the map?

Record your answer and fill in the bubbles on your answer document. Be sure to use the correct place value.

39. The diagram below shows a hot air balloon rising. Propane gas tanks are seen at the bottom of the balloon.

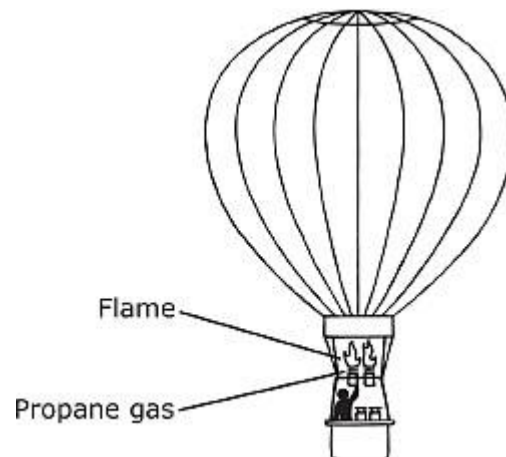

What energy transformations occur when propane gas is used to lift the balloon?

- A. Mechanical → light → chemical
- B. Chemical → mechanical → thermal
- C. Thermal → chemical → light
- D. Chemical → thermal → mechanical

40. An atom has 25 protons, 30 neutrons, and 25 electrons. What is the charge of the atom's nucleus?

- F. +25
- G. +30
- H. -25
- J. -30

41. Sometimes tectonic plates do not move easily past one another, and the plates become stuck. Forces build up, and when the plates finally move, tension is released, as shown below.

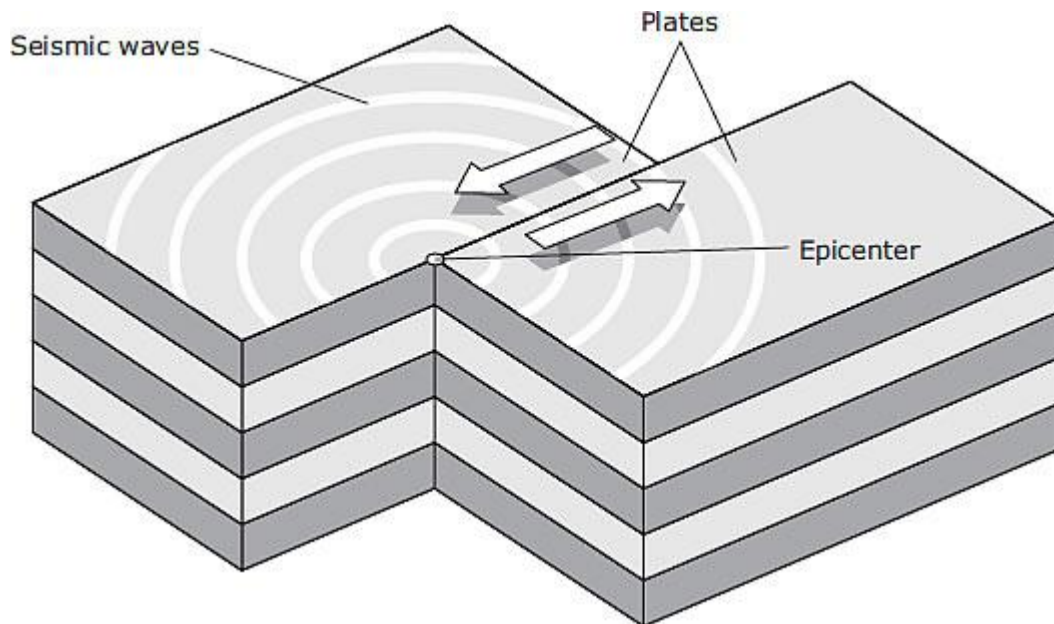

The sudden movement of the plates is caused by —

- A. the mass of the plates
- B. the weight of the plates

- C. unbalanced forces
- D. gravitational force

42. A student sets up the investigation shown below.

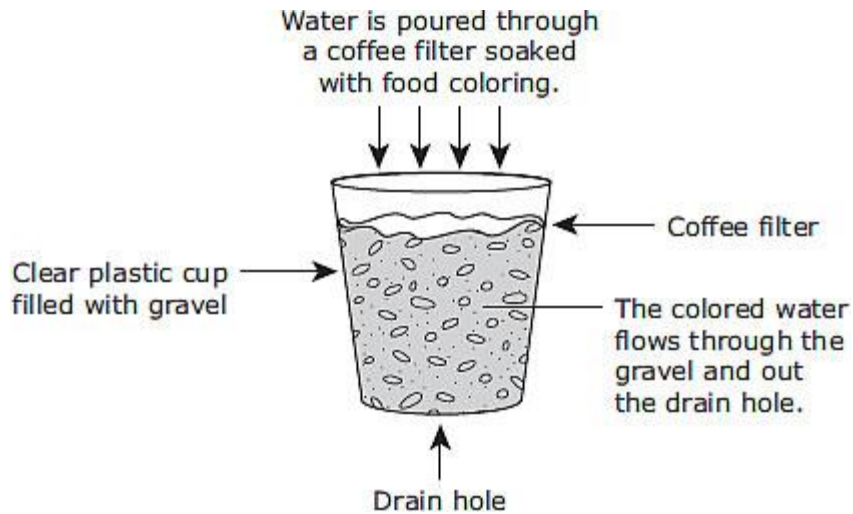

The movement of colored water through the gravel best models —

- F. condensation of water vapor
 - G. surface runoff of precipitation
 - H. conservation of water
 - J. pollution of groundwater
43. The Couch's spadefoot lives in Texas and has the characteristics listed below.

Characteristics of the Couch's Spadefoot

- Their pupils are vertical slits.
- Adults have mottled brown backs and light-colored bellies.
- Their eggs and tadpoles develop quickly in temporary ponds that form after rain.
- Adults live in holes they dig using special "spades" on their rear feet.
- Adults eat insects and spiders.

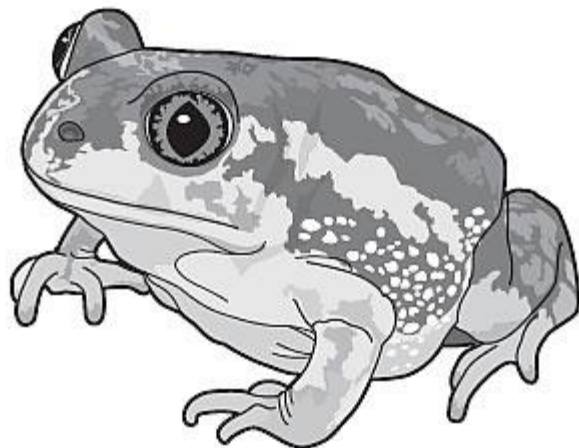

The Couch's spadefoot is adapted to a certain type of environment. Which of these resources is most likely scarce in this environment?

- A. Soil
- B. Sunlight
- C. Water
- D. Oxygen

44. How many atoms of oxygen are in a molecule of glucose($C_6H_{12}O_6$)?

Record your answer and fill in the bubbles on your answer document. Be sure to use the correct place value.

45. Baleen whales eat zooplankton by taking a large amount of water into their mouth. These whales use special structures in their mouth to separate zooplankton from the water. Because baleen whales eat zooplankton, they are classified as—

- A. producers
- B. predators
- C. parasites
- D. hosts

46. A student keeps a record of the phases of the moon for one month. On the first night of the student's observations, the full moon is visible in the sky. After the full moon, which of these phases will the student observe next?

- F. Waxing crescent moon
- G. Waxing gibbous moon
- H. Waning crescent moon
- J. Waning gibbous moon

47. The characteristics of a particular organism are listed below.

Characteristics of an Organism

- Is multicellular
- Is autotrophic
- Has cell walls
- Has cell nuclei
- Can reproduce sexually or asexually

In which kingdom should this organism be classified?

- A. Fungi
- B. Eubacteria
- C. Plantae
- D. Animalia

48. The chemical equation shown below represents a reaction that produces fuel for certain cars.

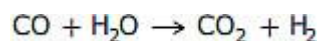

Which substance represented in this equation is classified as an element?

- F. CO
- G. H₂O
- H. CO₂
- J. H₂

49. The Hertzsprung-Russell diagram below shows how the brightness, surface temperature, and color of stars are related.

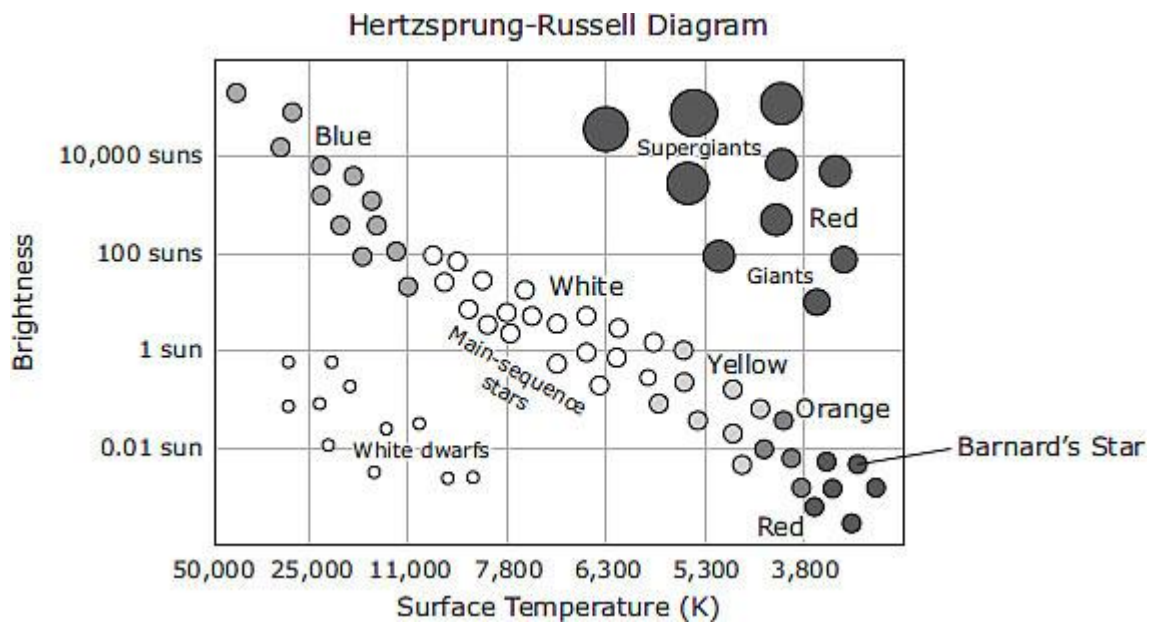

Which of these observations of Barnard's Star is most likely accurate?

- A. Barnard's Star is less bright than the sun, has a surface temperature below 3,800 K, and is red.
 - B. Barnard's Star is less bright than the sun, has a surface temperature above 3,800 K, and is red.
 - C. Barnard's Star is brighter than the sun, has a surface temperature below 5,300 K, and is yellow.
 - D. Barnard's Star is brighter than the sun, has a surface temperature above 5,300 K, and is yellow.
50. Some scientists studying aquatic plants notice that flooding often leads to a decrease in the rate of photosynthesis among aquatic plants. Flooding causes more sediment to be suspended in the water. The increased sediment concentration decreases the amount of light that reaches the plants. Why does a decreased rate of photosynthesis lead to a decrease in a plant population?

- F. Less water is available for absorption.
- G. Less tissue is available for plant growth.
- H. Less energy is available for reproduction.
- J. Less soil is available for leaf development.

51.

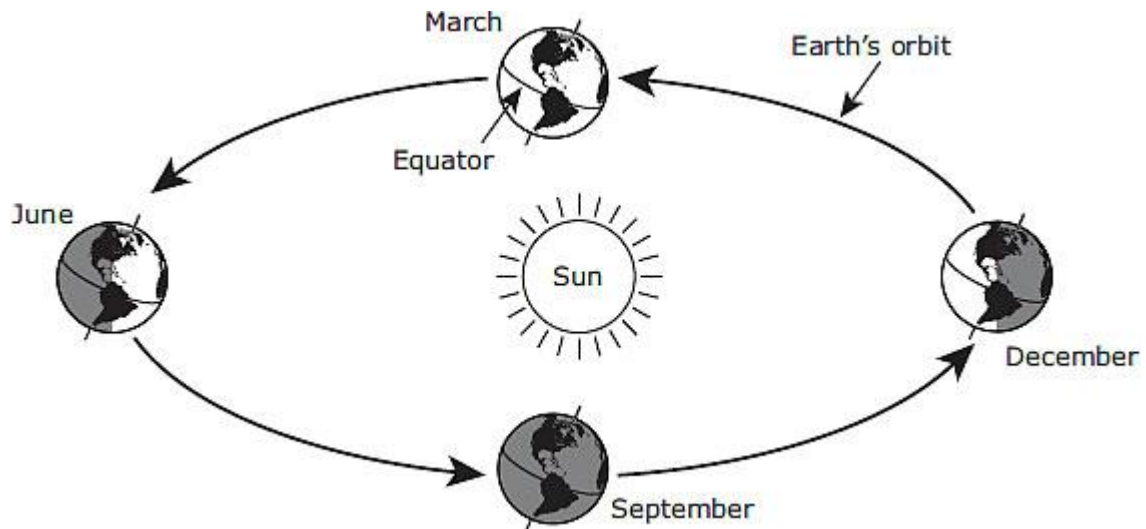

Earth would not have seasons if it —

- A. no longer tilted on its axis
 - B. stopped rotating on its axis
 - C. took an additional month to orbit the sun
 - D. revolved around the sun in the opposite direction
52. During an investigation, a student combined the two clear, colorless solutions shown below.

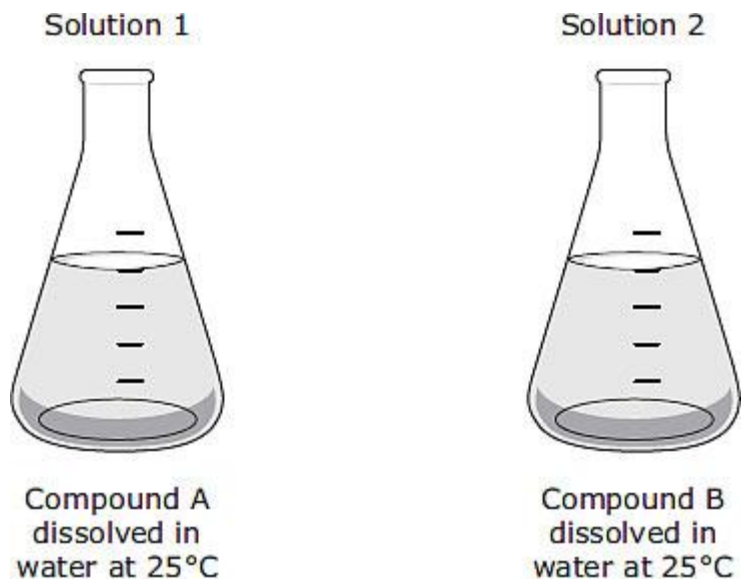

The student observed that the temperature changed from 25°C to 23°C when the solutions were combined and that a white substance rapidly formed and settled to the bottom of the container. What most likely happened to produce these results?

- F. One of the original compounds came out of solution.
 - G. The solutions reacted chemically.
 - H. Some of the water froze into ice crystals.
 - J. Rapid evaporation of water occurred, leaving a solid.
53. Why does Earth get more energy from the sun than from all the other stars in the universe combined?
- A. The sun is much larger than the other stars.
 - B. The sun is much hotter than the other stars.
 - C. The sun is much more dense than the other stars.
 - D. The sun is much closer than the other stars.
54. The diagram below shows a boat moving north in a river at 3 m/s while the current in the river moves south at 1 m/s.

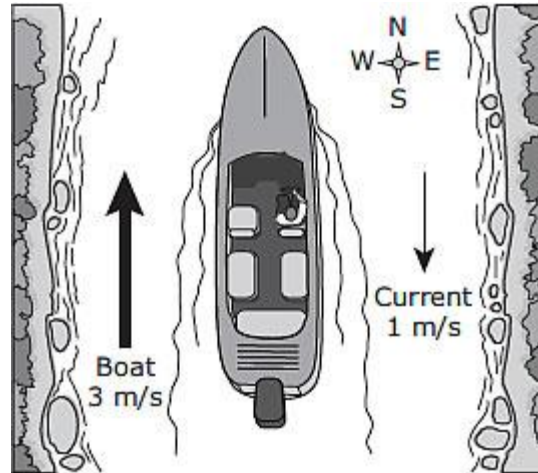

How will the boat be affected if it enters a part of the river where the current is moving south at 2 m/s?

- F.** The boat will move slower.
- G.** The boat will move faster.
- H.** The boat will stop.
- J.** The boat will move to the west.